



Committed to Cleaner Air

ANGUIL



Innovative Air Pollution Control Solutions

We understand the many considerations you and your company must address to achieve today's clean air requirements. Since the founding of Anguil Environmental Systems in 1978, we have had only one mission: to provide companies like yours with innovative air pollution control solutions that meet all of your objectives:

Guaranteed VOC, HAP, NOx compliance and odor abatement, reflecting your company's stewardship of our environment

Full compatibility with your process or industry

Low capital and lifetime operational costs, through years of worry-free performance

Today the Anguil companies are respected leaders in oxidation technology, with well over 1,600 fully compliant installations worldwide. We intend to remain in the forefront of our industry, thanks to the vision of our highly qualified, customer-driven people and the continuously advancing technologies they implement. It is a commitment you can count on, now and long into the future.



A handwritten signature in black ink that reads "Gene H. Anguil".

Gene H. Anguil
Founder and CEO

Committed to Cleaner Air

A leading global supplier of air pollution control solutions, Anguil Environmental Systems offers you not just one, but a **full range of proven technologies.** This enables our engineers to design the right custom solution for your company, an **unbiased solution** that optimizes the latest

technologies, instead of settling for a narrow range of predetermined options. Importantly, the installation of Anguil's oxidation systems is normally transparent, allowing your system to be integrated seamlessly with your ongoing process. Our family of oxidizers includes:

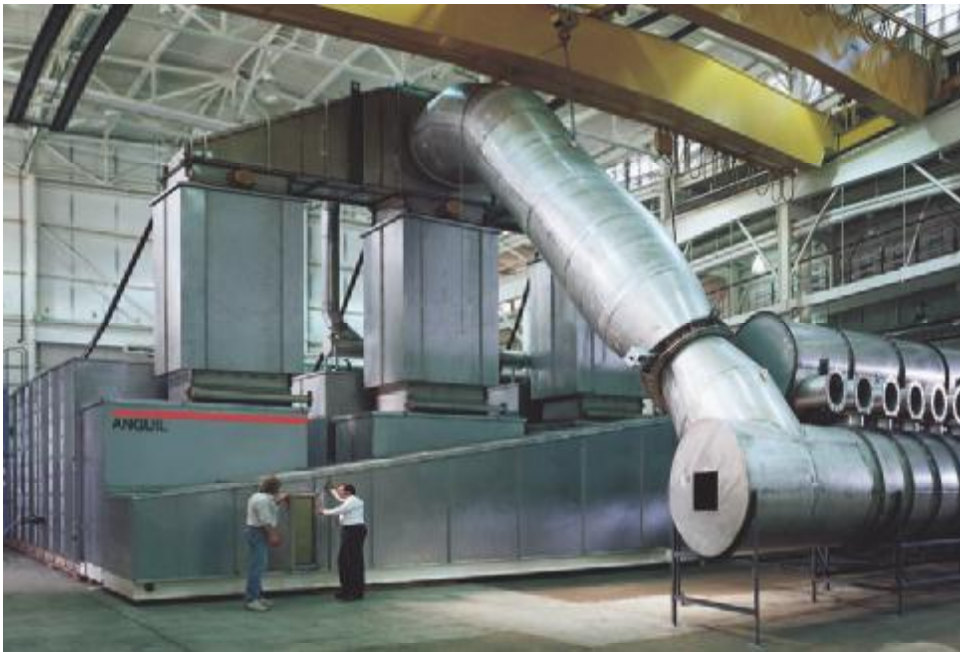

- Regenerative Thermal Oxidizers
- Regenerative Catalytic Oxidizers
- Catalytic Recuperative Oxidizers
- Thermal Recuperative Oxidizers
- Zeolite and Carbon Concentrators
- Halogenated Oxidizers/Acid Gas Scrubbers
- Direct-fired Thermal/Catalytic Oxidizers

Providing Successful Solutions for Multiple Industries and Applications

Baking & Food	Packaging
Chemical Processing	Paint Finishing & Production
Coating & Laminating	Petroleum Refining
Composites	Pharmaceutical
Engine Test Cells	Plastics
Ethanol	Printing & Converting
ETO Sterilization	Rubber Processing
Flexographic Printing	Semiconductor / Electronics
Foundry	Web Coating
Metal Decorating	Web Offset Printing
Odor / Opacity	Wood & Paper



Evaluate what is best for

your facility. Our field engineers will analyze your process emissions and obtain an understanding of your operational requirements through an **on-site inspection** and discussions with you and your consultants or engineers. Using this information, your Anguil team will develop a customized report pinpointing the critical issues and preferred solutions. They will also prepare



Advance Analysis & Technology Selection



a conceptual layout of the technology recommended for your company, using the latest CAD techniques. Because Anguil offers a complete range of technologies, you are assured that the best alternatives will be recommended, without prior bias for any single approach.

The analysis will be a valuable tool you can use to evaluate:

- Capital cost options
- Equipment alternatives
- Operational cost comparisons
- Assurance of long-term compliance

With careful advance planning like this, you are assured that your system will deliver the **cost-effective performance** you need today, and for many years to come.

Multiple Technologies. Unbiased Solutions.

Recuperative Catalytic Oxidizer System

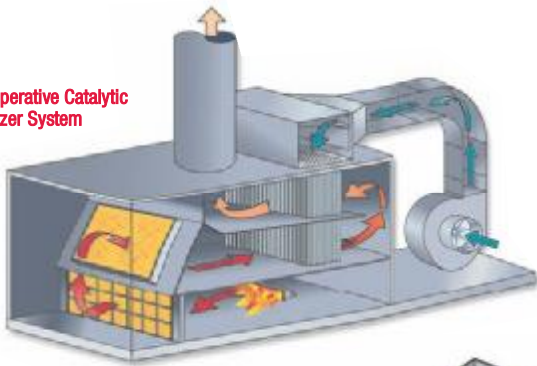

Regenerative Thermal/Catalytic Oxidizer System

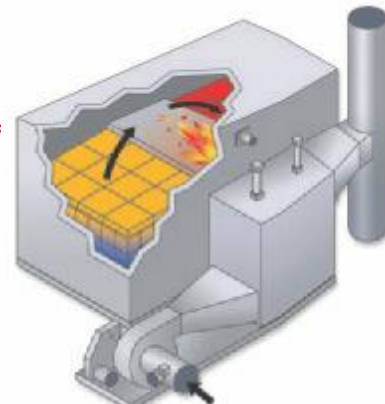

Integrated Rotor Concentrator and Oxidizer System

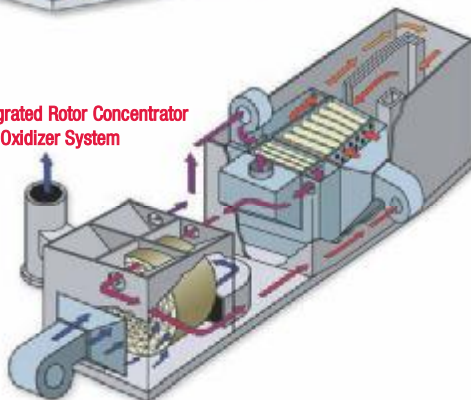

Thermal Recuperative Oxidizer System

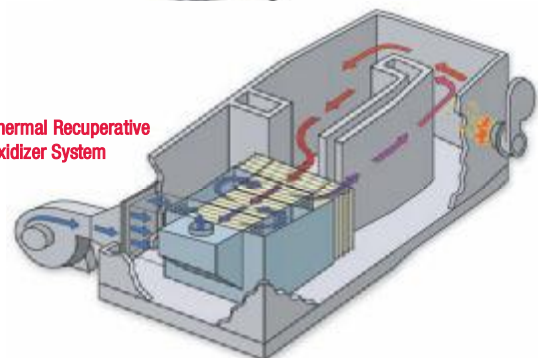

On-time delivery, fabrication and installation. We know how important it is for your new system to be delivered when planned, and to be installed with minimum downtime.

With this in mind, many of our systems arrive on-site as modules — pre-assembled, pre-wired, factory tested, and ready for fast, efficient installation.

Our installation team can provide full turnkey services, or, if you prefer, we'll work with your contractor. You'll be up and running, with an Anguil-assured system that, from day one, will put you in full compliance – guaranteed.



Fabrication and Installation



All Anguil systems are built by expert craftsmen using the best materials for your application.



Throughout fabrication, your new Anguil system is subjected to rigorous integrity testing, including a thorough final inspection and pressure testing before it is released for delivery to your site.



Every Anguil unit is equipped with a sophisticated Programmable Logic Controller that monitors your system at all times. If a fault occurs, you can see at a glance what it is, along with a possible solution — far superior to relays and warning lights that are unable to provide helpful remedial information.

www.anguil.com

Service for Your Investment

Whether it is still on the drawing boards or has been on site for years — your Air Pollution Control System represents two things: a Significant Investment and a Long-term Commitment.

Anguil offers a complete selection of post-installation services — allowing you to get the most from your investment, over the entire life of the system.

Anguil has more than two decades of experience supplying the full range of oxidizer technologies and servicing thousands of oxidizers of all makes and models. It's your assurance of the performance improvements you want...

- Increased Flow Capacity
- Improved Destruction
- Improved Capture

with the results you want...

- Reduced Operating Cost
- Improved Reliability

...when you want them.



Anguil training program.

Technical Support



Anguil customer and technician communicating via Remote Telemetry.

Prompt Technical Support, 24 Hour Emergency Service

Call any time, day or night, for prompt assistance on any make or model oxidizer or scrubber system.

Our experienced technicians are on duty and ready to help with the precise technical information you need, and fast delivery of parts from our well-stocked inventory.

Online Diagnostics

Anguil systems now come standard with Remote Telemetry, our most popular retrofit to existing systems. You can receive fast, accurate diagnostics of your entire system via direct modem connection to our computer base. It's like having your own Anguil engineer on-site.

Anguil, Your Single Source for Parts and Service

- Preventive Maintenance Evaluation (PME)
- Spare Parts Packages
- Catalyst Services
- Operating Cost Reviews
- Heat Exchanger Diagnostics
- Destruction Efficiency Measurement
- Operator Training

Choose any one of these services individually, or let us tailor a Service Program to fit your needs.

Anguil experience and service — powerful allies in protecting your investment.

www.anguil.com

Advantages with **ANGUIL**



➤ **Guaranteed Compliance with EPA, State, Province and International Regulations**

➤ **Proven Air Pollution Control Solutions**

➤ **Full Range of Technologies**



➤ **Cost-Efficient Performance**

➤ **Multi-Industry Experience**

➤ **Low Maintenance**



➤ **Upgrades for Existing Pollution Control Systems**



Committed to Cleaner Air

ANGUIL provides compliance solutions worldwide, including engineering, fabrication, installation and technical support. Please contact us for the experienced Anguil Representative in your area, and for prompt technical assistance with your Air Pollution Control equipment or compliance questions.



ANGUIL

Anguil Corporate Headquarters

Anguil Environmental Systems, Inc.

8855 N. 55th Street / Milwaukee, WI 53223
Tel 414-365-6400 / Fax 414-365-6410
sales@anguil.com

Global Technologies

Anguil Environmental Systems, Inc.

8855 N. 55th Street / Milwaukee, WI 53223
Tel 414-365-6430 / Fax 414-365-6410
www.globaltechnologiesinc.com

A worldwide leader in subsurface remediation treatment, supplying advanced, reliable, and user-friendly thermal and catalytic oxidizers and integrated extraction systems.

Anguil East Region Office

Anguil Environmental Systems, Inc.
88 E. Main Street / Mendham, NJ 07945
Tel 973-543-8923 / Fax 973-543-8924
sales@anguil.com

Anguil Europe

Envirocombustion Systems Ltd.

Home Farm,
Cash Lane,
Eccleshall
ST21 6HW United Kingdom
Tel + 44 1785 284001 / Fax + 44 1785 284002
Designs and manufactures VOC control systems and subsurface remediation treatment throughout Europe.

Anguil Asia

Anguil Environmental Asia, Ltd.

9F-3, No.321, Fu-Hsin South Rd.
Sec. 1, Taipei
Taiwan, R.O.C.
Tel 886-2-2705-2886 / Fax 886-2-2709-0448
sales@anguilasia.com
www.anguilasia.com
Designs and manufactures VOC control systems and subsurface remediation treatment throughout Asia.

Your Anguil Representative

www.anguil.com